

# 10 reasons to use a... Pressure Sensor Checklist

## Pressure Sensor Checklist

By Steve Smith  
Gary Casey

Directors  
Custom Sensors & Technologies

**N**o matter how many times pilots get ready to take off, they always refer to their checklists. That way they don't forget something fundamental like deploying the landing gear. In the same spirit, checklists are used to select the correct pressure sensor for an application.

"New Application Checklists" should be used to insure that sensor vendors don't overlook something fundamental when supplying sensors or transducers for specific tasks. The checklist that follows captures a number of important factors used to specify the correct pressure sensor for an application. Pressure sensors are generally configured by ten main product specifications, which form the basis of the checklist recommended here.



**1. Pressure range:** Determining what pressure range to use is not always as simple as it sounds. For example, an engine lubrication system may normally operate at gage pressures from 0 to 100 psig (where the "g" indicates gage reference). However, when oil is cold, it's often more viscous and the pressure may exceed 100 psig. Should you specify the

normal operating pressure or the maximum possible pressure? The answer relates to what pressure range is important to you. If you don't need to know when the pressure exceeds the normal range then why measure it? As long as the sensor is not damaged by the higher pressure, it may be better to limit the measured pressure range to 100 psig.

What about when an absolute pressure sensor is used together with a barometric sensor in the same system? What pressure range should be specified then? Zero (0) to 115 psia (absolute) where the extra 15 psia offsets standard atmospheric pressure? Standard atmospheric pressure is actually 14.7 psi, correlating to the average pressure at sea level. If the engine will also be operated at higher elevations then it makes sense to specify the lowest likely atmospheric pressure. In this particular example, the final pressure range could be 10 (equating to the lower pressure found at high elevation) to 115 psia (including the extra 15 psi to offset 1 atmosphere).

**2. Type of pressure to be measured:** There are different types of sensors available to measure different types of pressures. Virtually all sensors start out measuring *differential pressure*. Some type of membrane or diaphragm is exposed to the pressure to be measured (air, oil, fuel, etc.) on one side. Then there is another pressure on the other side of the diaphragm (quite often atmospheric pressure). The deflection of the diaphragm depends upon how much pressure

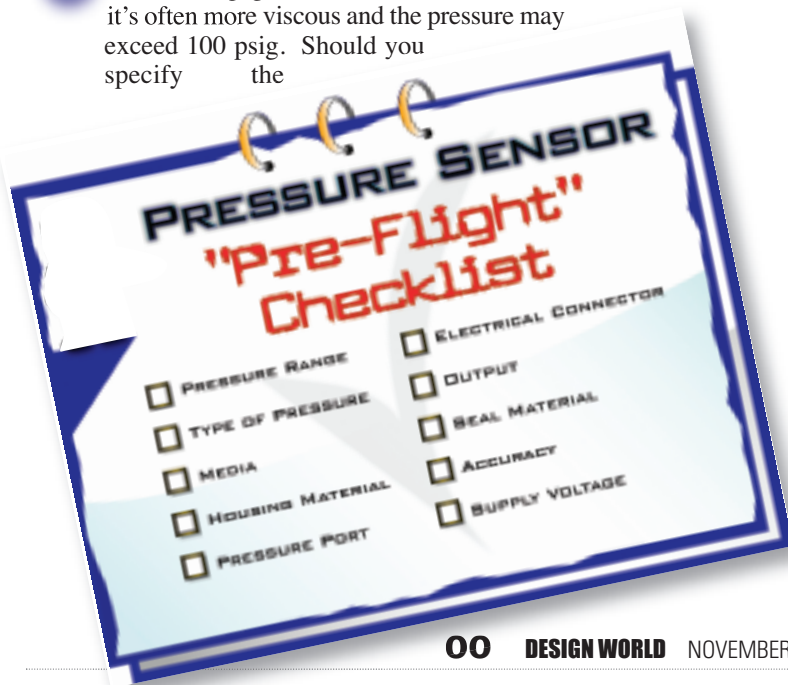
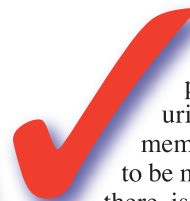

it is exposed to. If the back-side is exposed to atmospheric pressure then the sensor is said to measure *gage pressure* (the name of this pressure is derived from mechanical “gages” that indicate pressure relative to the atmospheric pressure around the gage). If the “back-side” of the diaphragm is exposed to a fixed, known pressure then that sensor is an *absolute sensor* because it measures the **absolute** pressure of the media. If the back-side is exposed to another media the sensor is said to be a *differential pressure sensor* because it measures the difference in pressure between the two media.

Absolute sensors are often less costly and more reliable than either gage or differential sensors. This is because the back-side of the diaphragm is sealed and does not have to contend with the environment. The back-side of a gage sensor is exposed to the atmosphere while that of a differential sensor is exposed on both sides to media possibly less benign than air.

The specific type of pressure to be measured is important to understand. Some sensor technologies work well for one type of pressure measurement but not for others. For example, engine-oil-pressure measurement typically demands a gage sensor since the lubrication system is pressurized relative to atmospheric pressure. The same is true of an air-brake system. However, if the overall system incorporates a barometric pressure (BAP) sensor, then atmospheric pressure can be subtracted from the pressure measured by an absolute sensor, effectively creating a gage measurement. Remember, a gage sensor measures the difference between the surrounding atmospheric pressure and the media pressure. This is particularly important in vehicle applications when vehicles move between sea level and high altitudes like mountain passes.

**3. Media:** It’s important to specify all the possible variations of the media to be measured. For example, air could be perceived as a relatively benign media, but what about humidity? Could moisture in the air condense and possibly freeze? Are there traces of corrosive contaminants in the air? The true media needs to be understood so that proper construction materials are chosen for the sensor package.

**4. Housing material:** Brass pressure ports and Ultem® or Valox® electrical connectors are common materials used in sensors. Stainless steel and materials such as nickel-plated brass are often used as well. Plastic composites might be specified to minimize weight and cost. Housing material should be selected only after careful analysis of compatibility with the operating environment and media being

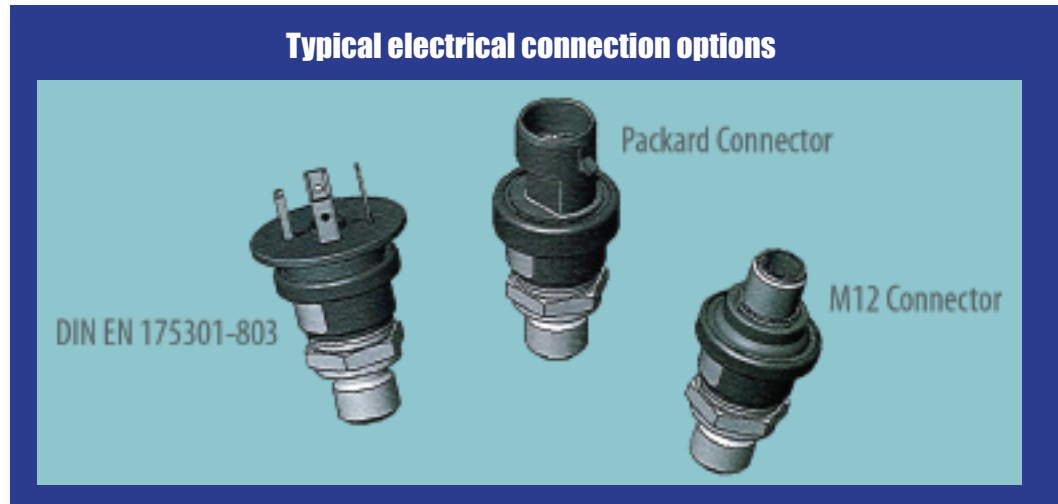

measured. For instance, brass and stainless steel are often used when refrigerants are present. Brass and stainless are often used in marine applications where salt-spray is an issue. Plated parts are used when cosmetic considerations are important.

**5. Pressure port configuration:** There are a host of pressure port configurations designed for specific applications. Does the application require male or female threads? Should a flange mount or tube-fitting port be specified? Common ports include NPT (National Pipe Thread) such as 1/8-27NPT and NPTF (the “F” designating dryseal). SAE and metric straight threads are also commonly specified, both of which typically require external o-rings. There are various quick-release ports such as Prestomatic® and Legris. Barbed-end hose fittings and more can be specified among the hundreds of options. The application should dictate the port requirement.

**6. Electrical connection:** Does the requirement call for an integral connector, molded cable assembly, flying leads, terminal pins, or a hermetically sealed (MIL-Spec) connector? Common connectors affixed to most sensors on the market today include commercially available Packard, DIN, Tyco, Framatome, and Deutsch. Many others are available, some of which are proprietary. Cost, performance, and your specific needs all play a role in the decision process. Insert electrical connection graphic near here.

**7. Output:** Amplified voltage, regulated, current loop, frequency, and digital are among the many outputs to choose from. The most common is 5 Vdc *ratiometric*. Output voltages generally range from near 0 Vdc at the lowest pressure to something nearly equal to the full supply voltage at full pressure. A common output specification is 10% of supply voltage at the minimum

## Typical pressure connection options

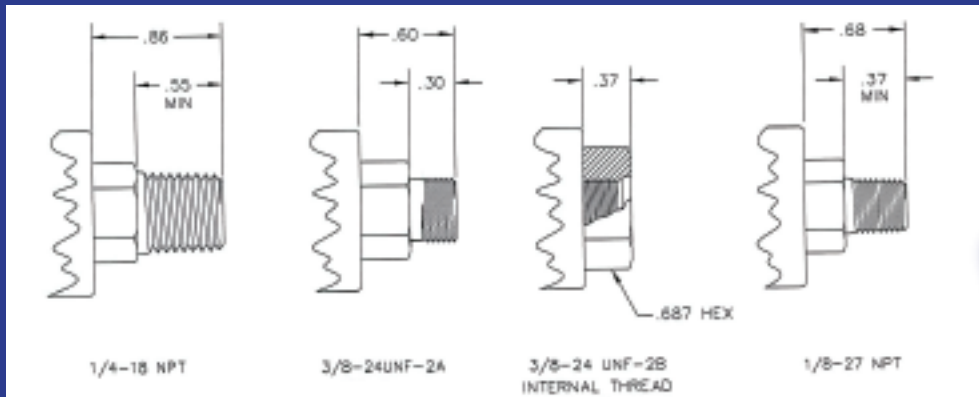

**8. Seal material:** Compatibility with the process media to be measured and the installation environment are key factors when selecting an o-ring seal. If the wrong material is selected, the seal may fail. Fluorosilicone, Fluorocarbon (Viton®), neoprene, nitrile, and ethylene propylene are the most commonly selected o-ring materials.

operating pressure and 90% at the maximum. So if the supply voltage is 5 Vdc, the lowest measured pressure would equal an output of 0.5 Vdc and fullscale pressure would equal 4.5 Vdc. This is a typical analog output, but not an official standard.

*Ratiometricity* is often mentioned when discussing output. This word means that the output voltage will vary in proportion to changes in the supply voltage. Ratiometricity itself is not perfect and there is usually a specification for the allowable ratiometricity error. Another frequently specified analog format is a current-mode output or 4-20 mA. At the lowest pressure, current output is at 4 mA and at the highest pressure the output is 20 mA. The sensor is a two-wire device and the output is insensitive to moderate supply voltage changes – a big advantage in many industrial applications.

There are a number of digital output formats including, *PWM (Pulse Width Modulated)*, several *Controller Area Network (CAN)* protocols and, *Serial Peripheral Interface (SPI)*. A common CAN protocol used in vehicle applications is J1939.

## Pressure functions

One important specification is the transfer function. This defines the correlation of output to pressure. Once the upper and lower pressure limits (null and full-scale pressure) and the degree of resolution are determined, a transfer function is selected to meet the application's requirements.

Other important specifications in selecting pressure sensors include electromagnetic compatibility (EMC), proof and burst pressure requirements (proof pressure is where the sensor stops working temporarily and burst pressure, as the name suggests, indicates where the part permanently breaks), storage and operating temperature ranges, and durability (10 million cycles, as an example).

**9. Accuracy:** The required accuracy and how it should be specified depends upon the application. 3% total accuracy was once the norm, but in today's market there has been a shift to a 2% requirement. 1% accurate pressure sensors are gaining in popularity as the cost differential for the higher accuracy shrinks due to the competitive nature of the sensor industry.

What are the components of accuracy? There are several which include offset, span (slope or gain), repeatability, reproducibility, hysteresis, and drift. Probably the most common accuracy specification is a percent of span that can be expressed as a Total Error Band (TEB) specification including hysteresis, drift, and temperature effects.

**10. Supply voltage:** The industry standard is 5 Vdc,  $\pm 0.25$  Vdc. However, based upon application-specific requirements, other voltage requirements may be necessary. Consult with the electrical engineer responsible for sensor installation when determining your supply voltage.

**Understand your application** thoroughly before trying to identify the best possible pressure sensor to meet your needs. Know the overall system requirements and the required performance characteristics. Some sensors will be installed in systems that are prone to produce dangerous pressure spikes. If this is the case in your system then it begins to indicate the type of base sensing technology to choose. For example, air pressure systems often mitigate overpressure conditions because air compresses. Hydraulic applications, on the other hand, can generate harmful pressure spikes that require special sensor designs.

When it's time to specify a pressure sensor for your particular application, don't forget to use this checklist. **DW**

Custom Sensors & Technologies  
[www.cstsensors.com](http://www.cstsensors.com)