

Application Note

Pressure Sensor Fundamentals Associated with Hydraulic Systems

June 2009

Hydraulic systems use incompressible liquids with low activation pressure to control high pressure actions. From the brakes that stop our automobiles, to fork lifts that move and stack heavy boxes in warehouses, to the bulldozer moving dirt for the new highway, hydraulic applications are all around us. When the warehouse operator pulls the lift lever, he activates a hydraulic pump that delivers fluid under pressure to a piston to lift the load. The amount of fluid and pressure are a function of the load. A heavier load requires the pump to increase the pressure on the fluid to lift the load and the higher the load is lifted, the more fluid is required to push the piston up.

The ability of a hydraulic system to match the amount of work done by the pump to the size of the load is one of the defining characteristics of a hydraulic system. In most systems, under no load situations, no energy is expended by the hydraulic pump. A light load may require only 15% of the capacity of the pump while heavy loads can push the pump to the limit. In that way, the amount of energy used to run a hydraulic system is dependent on the load. The pump does not work full time at a fixed rate to lift a light load.

There are few practical alternatives to hydraulics. Mechanical systems could be designed with motors and gears but those systems would have to be sized for the maximum load and would be large and inefficient. Pneumatics or air pressure could be used in some applications but air compresses and any leak would immediately deflate the system. The air compressor size and power requirements would be significantly larger and more complex than the hydraulic system. While hydraulic systems do spring leaks, it takes time to drain all the fluid out of a system through a leak and it can be detected and repaired before damage is done to the operator or system.



Fig. 1:
Kavlico P4000
and P250
Pressure Sensors

Pressure sensors play a key role in hydraulic systems. They can detect leaks in the system and insure that enough pressure is available on demand to perform the job required. They can provide a signal when the pressure exceeds system design parameters or if the load is too heavy for the system to safely handle.

Hydraulic systems are characterized by pressures of 6,000 PSI and above. Pressure spikes caused by the pumps and the applications can be significant and can easily double the pressure that the sensor is expecting to see causing sensor failure if not anticipated. Many times these pressure spikes are of very short duration and require specialized equipment to detect. The operating environment may see high vibration, severe shocks and extreme temperatures. Because of the severe environment, the technology used to build rugged and reliable pressure sensors must be very robust. Pressure sensors such as Kavlico's P4000, PT250, and P5000 used in hydraulic systems use welded, stainless steel construction. Pressure sensors that use elastomeric compounds for the main media seal present an opportunity for the seal to become the weakest link and rupture, creating hydraulic fluid leaks. In addition, the seal material may be incompatible with additives or impurities used to optimize the base fluids.

Piezo-Resistive based sensors such as the Kavlico [P4000](#) and [P250](#) (Figure 1) use welded oil filled headers with stainless steel isolation diaphragms to protect the sense technology. (Figure 3) is a cross section of the pressure media interface for that type of product. The sense element is a high pressure 3,000 to 6,000 PSI piezo-resistive silicon MEMS device (PRT). The PRT device consists of 4 resistors connected in a Wheatstone Bridge configuration. It is mounted on a header with glass feed-throughs for the external connection to the leads of the silicon chip. The header is welded into a stainless steel housing with an isolation diaphragm. The header structure is filled with silicon oil and then sealed. As pressure is applied against the diaphragm, it is transmitted to the element by the incompressible oil. The MEMS device provides an output proportional to pressure that can be amplified and conditioned by an ASIC inside the sensor body. The structure can be made more robust by adding a pin hole sized snubber at the end of the housing thread. This tends to damp out many

Application Note

Pressure Sensor Fundamentals Associated with Hydraulic Systems

June 2009

of the pressure spikes by providing a restriction followed by an expansion chamber inside the thread in front of the diaphragm. These types of pressure sensor are optimized for pressure ranges between 1,000 and 5,000 PSI and are appropriate for less price sensitive medium to lower volume applications.

Higher volume and higher pressure applications are serviced by thin film technologies such as those found in the Kavlico [P5000](#) (Figure 2) series. The cross section of a thin film unit is shown in (Figure 4). A stainless steel piece is hollowed out to provide a thin diaphragm and materials are deposited on the top of that piece of steel. Resistors are implanted into the thin film in a Wheatstone Bridge arrangement and the pressure applied to the hollowed out side of the steel is transferred to those resistors, upsetting the bridge. The thin film elements are welded into stainless steel housings and appropriate signal conditioning is added to complete the sensor construction. It is not uncommon to find thin film elements rated as high as 20,000 PSI which would be impractical in other sensor technologies.

The electrical, temperature and stability performance of the product is defined by the materials used. The unit output is smaller than that of a comparable silicon PRT structure and must be amplified to a usable output voltage range. Nickel Chromium films are widely used by many suppliers. Newer Titanium Oxynitride (TiON) films used in the P5000 provide almost twice the electrical output per applied pressure as more conventional materials allowing for higher stability under high temperature operation.

There is no single best approach for all hydraulic pressure sensing applications. Maximum pressure range, cost targets, physical size, output configuration, safety considerations and temperature range are all factors that must be evaluated in any system design.

To find out more about Kavlico sensors for Hydraulic applications check out the Kavlico website at: [Hydraulics](#).



Fig. 2:
Kavlico P5000
Pressure Sensor

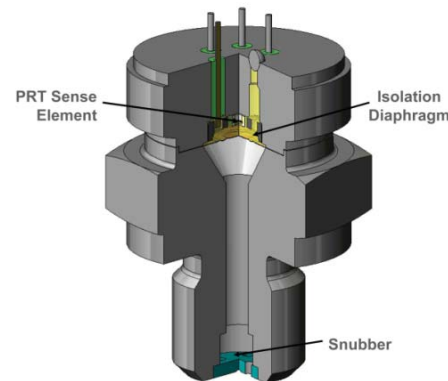

Fig. 3:
Oil-Filled PRT
Technology

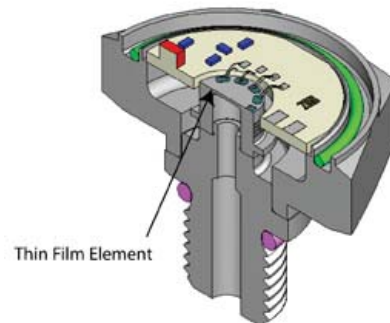

Fig. 4:
Thin Film
Technology

For more information contact:

Kavlico

14501 Princeton Ave., Moorpark, CA 93021

Tel: (805) 523-2000 – Fax: (805) 523-7125

Web: www.kavlico.com – E-Mail: sales@kavlico.com